

Advantage ReTurne

Energy recovery system

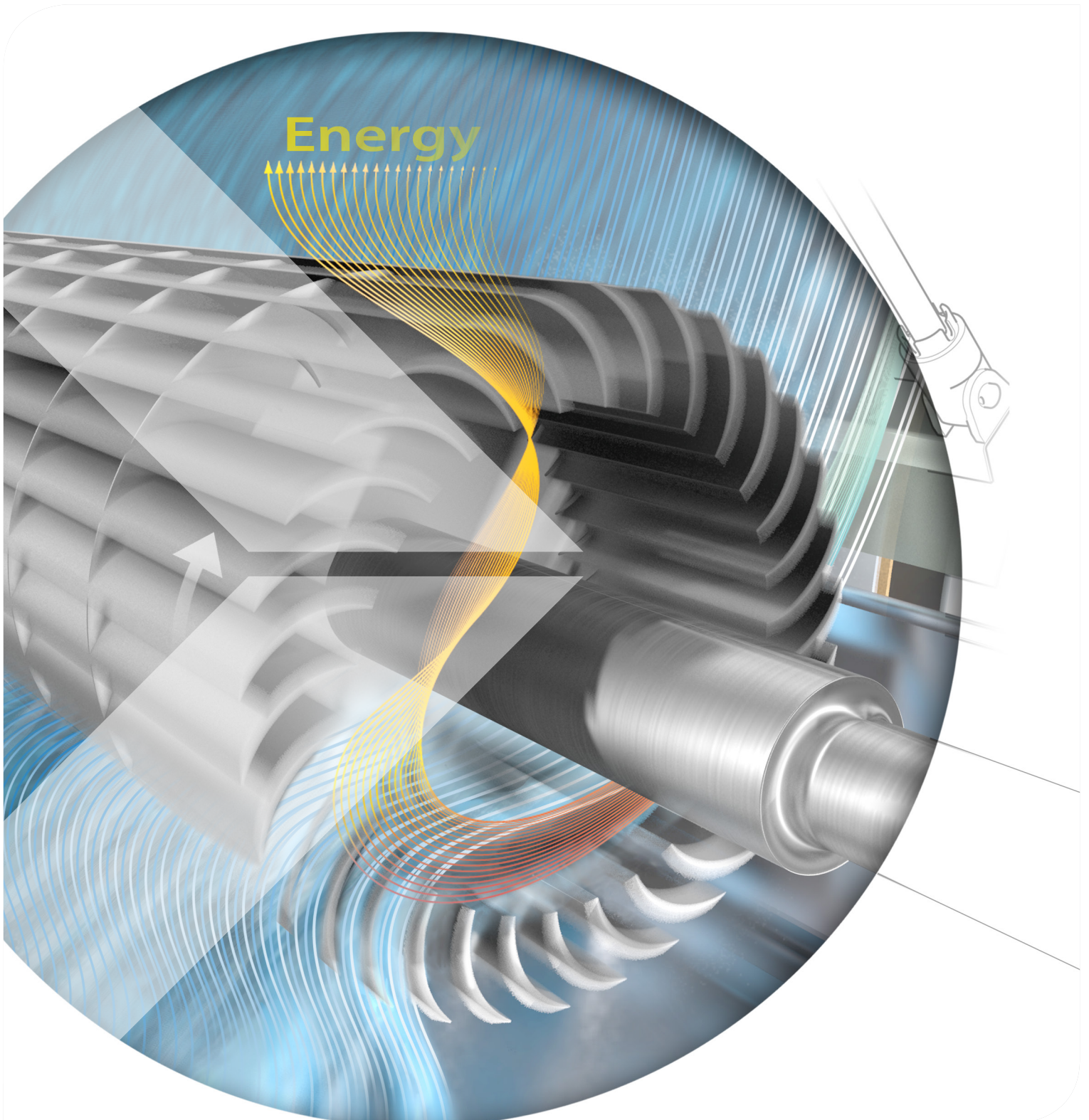

Advantage ReTurne installed in forming section

- Recover 50% of the Headbox Jet energy
- No impact on the tissue making process
- Easy to operate and low maintenance need
- Two mode flexibility - can be operated in energy recovery mode or by-pass mode

Recover 50% of the headbox jet energy

Why waste useful energy, when it can be recovered? The normal value of the headbox jet power is around 1000 kW for a 5,5 meter wide tissue machine, depending on slice opening, width and jet speed. This means that we use approximately 7000-8000 MWh during a year.

Raise energy efficiency to a new level

The Advantage ReTurne energy recovery system is a valuable contribution to Valmet's portfolio of energy efficient equipment and services for the tissue making process. It is raising energy efficiency to a new level, returning energy back into the process and cutting costs.

The heart of this energy saving innovation is a turbine, installed in the save all tray. The turbine is connected to a generator and located close to the headbox jet to recover as much energy as possible. When the water leave the headbox and passes through the fabric, a guide plate controls the water flow.

The guide plate ensures that the power of the water flow hits the turbine blades in the most optimize angle to reach the highest possible efficiency. The clever design of the guide plate ensure efficient and trouble free de-watering and formation of the paper. It is also possible to move the guide plate into by-pass position, where the process water just passes through the save-all as in normal process.

Return the electrical power into the process

The turbine is connected to a generator which converts the water flow power to electrical power and controls the rotational speed of the turbine. The electrical power that is generated passes through a frequency converter before it supplies the DC bus and sectional drives with the recovered power.



Recovery potential in figures

- Headbox outlet width 5,5 meter
- Machine speed 1900 m/min
- Lip opening 12 mm
- Jet power 1050 kW

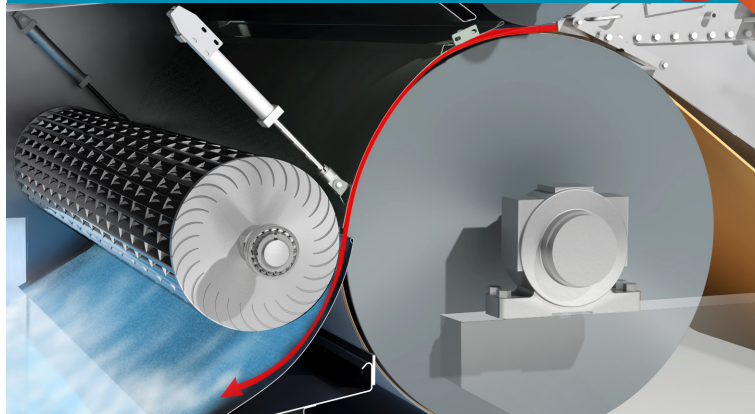
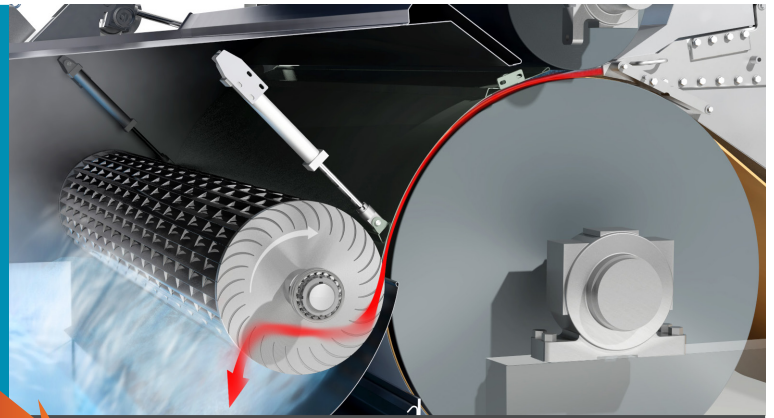

= recovered power 525 kW
 = Annual savings 4296 MWh
 = 429,000 EUR/Year*

*based on energy cost of 0.1 EUR/KWh

Trouble free tissue process

The Advantage ReTurne energy recovery system has been developed to achieve the best energy saving potential without disturbing the tissue process and production. Much effort has been put into the design work to make the whole forming section fail-safe. Its two mode flexibility allows operations in energy recovery or by pass mode.

The need of maintenance is limited and it is easy to integrate in the process.

tissue machine at our Technology Center.

Significant saving potential

The Advantage ReTurne energy recovery system has been developed at Valmet's Tissue Technology Center in Karlstad, Sweden. The functionality has been verified in several customer projects as well as in trials in the

The results confirm that it is possible to recover 50% of the energy, in some cases even more. For the earlier example with the 5,5 meter wide machine it means that about 3500-4000 MWh can be returned.

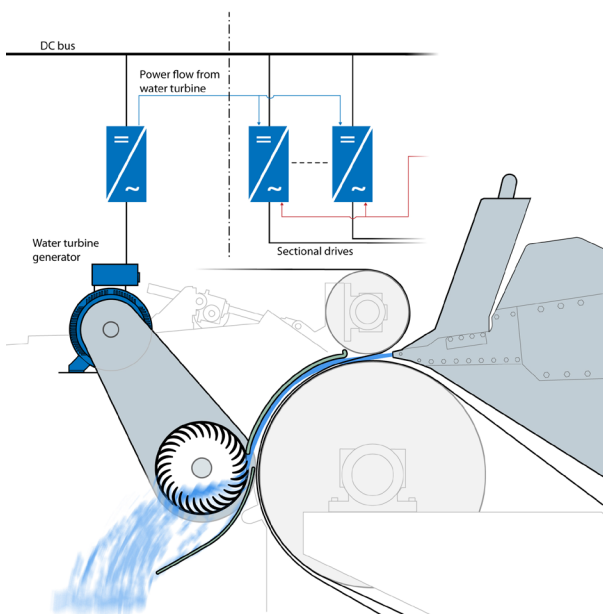

Schematic wiring diagram

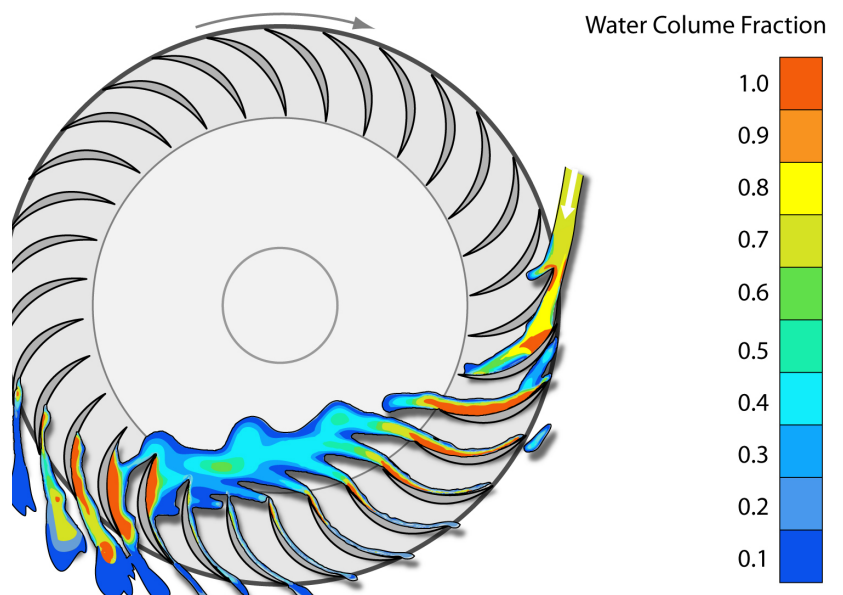

CFD simulation of cross flow water turbine

Over 150 years of experience within the pulp and paper industry has resulted in Valmet becoming the global leader in tissue making. We deliver the most production capacity with the largest installed base of tissue making machines worldwide.

We strive to ensure that tissue quality, knowledge and process technology, as well as our wide scope of service, continue to drive mutual success.

Join us to become
Best in Tissue!



Contact us

Valmet AB, Karlstad, Sweden
Tel.: +46 54 171 000

Valmet S.p.A, Gorizia, Italy
Tel.: +39 0481 528 311

Valmet Inc, Biddeford, USA
Tel.: +1 207 282 1521

Valmet Inc., Norcross, USA
Tel.: +1 770 263 7863

Valmet Ltd., Beijing, China
Tel.: +86 1065 6666 00

e-mail: tissue.info@valmet.com

www.valmet.com

Advantage ReTurne is a registered trademark in European Countries, USA, Brazil, China, Japan and Korea
Specifications in this document are subject to change without notice.
Product names in this publication are all trademarks of Valmet Corporation.

